

93 dodge dakota repair manual pdf

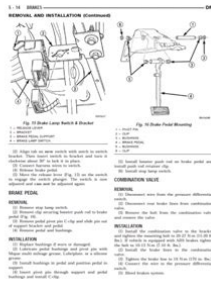
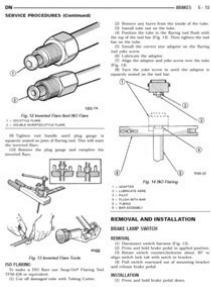

File Name: 93 dodge dakota repair manual pdf.pdf
Size: 4616 KB
Type: PDF, ePub, eBook
Category: Book
Uploaded: 1 May 2019, 13:27 PM
Rating: 4.6/5 from 725 votes.

Download Now!

Please check the box below to proceed.

I'm not a robot



reCAPTCHA
Privacy - Terms

dakota repair manual pdf, 1993 dodge dakota repair manual, 93 dodge dakota service manual pdf, 1993 dodge dakota service manual pdf.

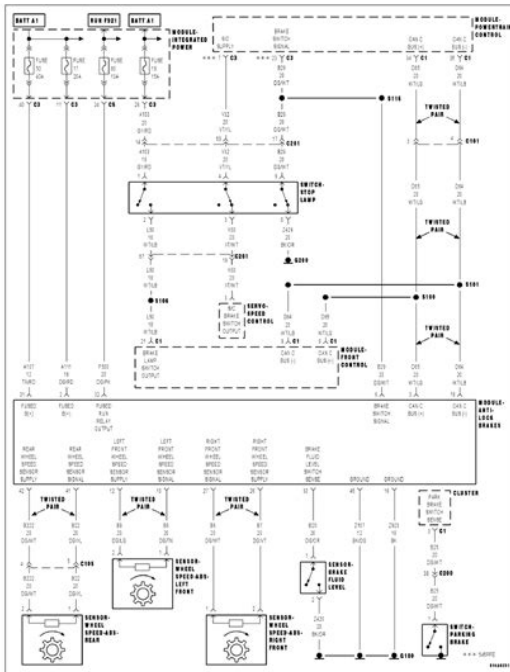

This refers to cars that participated in competitions, and it is these wheels that have contributed to the evolution of rims. This is a very lightweight rim and is better for general driving as opposed to racing. It works well with different models of cars. The BBS Super RS is made of forged aluminum and has an eccentric multispoke design. The style can be best described as “old school” and is meant for giving your car the classic look. This is especially a great rim if you are a classic car or luxury car enthusiast. As such, they are not cheap, but if you’ve got a luxury car or a classic car, why not go a step above. Instead of the standard spoke aesthetic, you will notice the rather oddshaped rings that replace the spokes. This may seem unusual at first, but it’s what adds to the appeal of these rims. You can find a standard looking rim, or you can go for one that is wild if your car’s personality suits it! If you are into customizing your car and standing out from others, you may wish to consider an ADV1 Rim. Additionally, it provides airflow for cooling. If you drive an American classic racing car, you may well find that the American Racing Vector is best suited for it. They are on the pricier side, in the thousanddollar range, so they are best suited for serious racing enthusiasts. While these are no longer in production, you may be able to still find them available for purchase. Usually, a store that specializes in vintage rims will carry these in stock. As they are a rare commodity, so you can really stand out if you add a set of these to your car. These are windmillshaped and are in a fivespoke design. They are now a rare commodity. While these never caught on, they were a favorite amongst models such as the 1993 Dodge Viper. These are multispoke designs that work well with classics such as the 1966 Jaguar EType. They also work with a variety of tires such as Dunlops, Daytons, and Borrani’s. Buy a rebuilt part or purchase a brandnew one. <http://pwr-tech.ru/userfiles/enforcer-digital-access-keypad-manual.xml>

DIGITAL
MANUALS
SERVICE MANUAL

PDF

Dodge Dakota

2003

- ✓ INSTANT DOWNLOAD
- ✓ EASY PAYOUT
- ✓ PDF FORMAT

I
N
S
T
A
N
T
D
O
W
N
L
O
A
D

You can rebuild almost any part available in a remanufactured version. Yes, the car owner instead of a shop. Therefore, we'll review the top three automotive parts you can rebuild yourself instead of replacing. In some cases an alternator will make noise which actually indicates the failure of one of the two bearings. A brandnew replacement alternator can be extremely pricey on some models. A overhauled unit is less expensive, but often less reliable. Sure, the auto parts store replaced it, but they don't reimburse you for the labor it takes to remove and replace the alternator two or three times. The alternative to a new or remanufactured part is to rebuild the alternator yourself. Personally, I search down the overhaul kit before I make the decision on whether I'm going to rebuild the part or buy a new one. If the kit is available, I look at what's included and then I make my decision from there. We don't have to get into diagnosing each individual component, because we might as well replace them all once we take the screws out of the case and open the alternator up. The high quality kits include complete instructions and most of the time you don't need any special tools. Unfortunately, just like my experience with rebuilt alternators, you don't always get a good replacement starter right out of the box. This especially true on German cars like the Mercedes Benz C Class or the BMW 5 Series automobiles. Diving a little deeper into the issue, you find these worn out brushes installed on high mileage automobiles. A complete overhaul kit for a starter can cost as much as a new part on some year, makes and models. They also include new front and rear bearings. Since the starter motor doesn't spin all the time like the alternator the bearings aren't usually the problem. The Armature is a heavy longlasting component and can often be cleaned or reconditioned. This applies to both foreign and domestic automobiles.

Another thing I inspect is the commutator bars on the armature. When the brushes wear out the carbon works into the spaces between the commutator bars. You want to make sure you can clean this out and there's no damage to the surface, because this is where the new brushes will ride. As in the case with the alternator a core charge is also due for a starter motor. The automotive parts company will return it to their factory where it's reconditioned and then resold to the next customer. The CV stands for constant velocity. Basically this is a large heavy duty universal joint that drives the wheels while they're turned and go up and down. The factory covers the CV joint on a front wheel drive car with a flexible rubber boot. After a couple of decades, this rubber begins to harden

and develop cracks. As the lubrication level decreases wear increases on the CV joint. Drivers of high mileage front wheel drive cars will often complain about a clicking or grinding sound from the wheel area when this situation occurs. The complaint is most evident when the car is taking off from a stop with the wheels turned. This includes the inner tripod joint that attaches to the transmission, the shaft, the outboard CV joint and the hub assembly. It seems kind of wasteful to replace this entire unit when the only bad part is the CV joint itself. However, with stiff competition, rebuilt driveshafts are often available for popular models at very reasonable prices. Since there's a bit of work involved in replacing just the CV joint you'll have to make this judgment call on your own. A basic set of snap ring pliers is usually the only odd tool that you might need. It's also recommended that you check your Dodge auto repair manual for the procedure for your specific model. When these old rides start running poor, getting rotten gas mileage or stall it might be time to rebuild the carburetor. Reconditioning this low tech fuel delivery system makes a great weekend project.

CAVITY	AMP FUSE	ITEMS FUSED	CAVITY	AMP FUSE	ITEMS FUSED
1	30 AMP	HEATER AND A/C BLOWER MOTOR	17		OPEN
2	30 AMP	C/BKKE POWER WINDOWS	18		OPEN
3	10 AMP	BACK-UP LAMPS, A/C CYCLING SWITCH	19		OPEN
4	5 AMP	ABS BRAKE SYSTEM	20		OPEN
5	20 AMP	POWER DOOR LOCKS			
6	12 AMP	HORN, TACHOMETER			
7	10 AMP	STOP LAMPS, BUZZER KEY-IN, SEAT BELT HEADLAMP, RIVAL MODULE			
8	30 AMP	TAIL LAMPS, PARKING LAMPS, SIDE MARKER LAMPS, LICENSE LAMPS, CLOCK, RADIO DISPLAY INTENSITY, PANEL ILLUMINATION LAMPS			
9	15 AMP	CIGAR LIGHTER			
10	20 AMP	WINDSHIELD WIPERS AND WASHERS			
11	20 AMP	TURN SIGNAL LAMPS, RIVAL MODULE			
12	10 AMP	RADIO			
13	4 AMP	PANEL ILLUMINATION LAMPS			
14		OPEN			
15	2 AMP	VEHICLE SPEED CONTROL			
16	5 AMP	GAUGES, LOW FUEL RELAY, LOW OIL LAMP, LOW WASHER FLUID LAMP, SERVICE REMINDER INDICATOR LAMP, TRANS OIL LAMP, BRAKE WARNING LAMP, MALFUNCTION INDICATOR LAMP, ANTI-LOCK LAMP, FUEL PUMP LAMP, ABS LAMP, TRANSMISSION OVERDRIVE LAMP, SEAT BELT BUZZER			

AMPS/FUSE	COLOR CODE
1	GRAY
2	PINK
3	BLACK
4	RED
5	YELLOW
10	RED
15	RED
20	RED
30	RED

<https://www.becompta.be/emploi/bose-ps48-iii-service-manual>

See if you should replace or rebuild an old carburetor. Who doesn't want one. Read our complete guide on the slickest American sports cars. The muscle car gives a driver power and speed but they also look slick! Sales of muscle cars in America have increased nearly 35% since 2005. Not all muscle cars are equal. Throughout history, a few muscle car manufacturers have withstood the test of time. While a few entries took a break from production, they always came back strong. These entries were chosen based on their prominence, history, and popularity. Many early variations of the Corvette were mainly convertibles. The Corvette is a sports car known for its slick design and powerful engine. The 2016 model includes a 6.2liter V8 engine. The Chevy Corvette Z06 for 2016 has a sevenspeed manual gearbox option. One beloved feature of newer Mustang models are the rounded headlights. One notable difference is the 5.0liter engine, with most competitors a 6.0liter is common. The 2017 Ford Mustang GT features 435 horsepower. Early generations saw this vehicle as a sleek and rounded sports car. This generation is when the longer front end design of the Camaro became the norm. Chevrolet decided a new generation would begin for this American sports car in 2010. The Camaro is now in its fifth generation of production. During its earlier generations, the Challenger would struggle to build a legacy against already established vehicles. In 2008, the modern Dodge Challenger would debut its 4th generation design. This newer Challenger is notable for its classic muscle car appeal. Click here to learn more about the history of American automobiles. Not only do they sound amazing at idle, but the further you push your foot down on the gas pedal, the better they sound. Although this upgrade remains popular, because of the noise a tuned exhaust header creates, there is actually a scientific reason to go for this aftermarket upgrade.

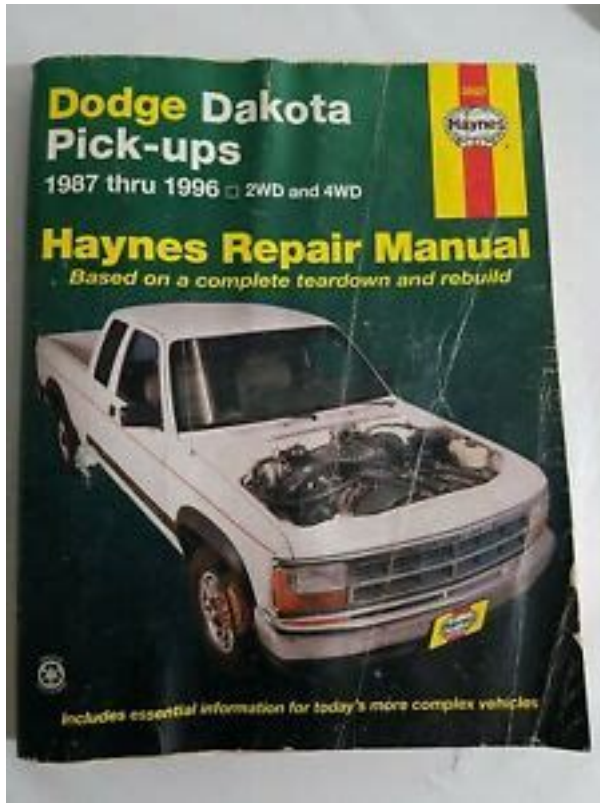

With that said, they also didn't see it as the best way to increase horsepower at the time. Nevertheless, installing aftermarket headers on some classic muscle cars presents major challenges. I installed a pair of Lakewood performance exhaust headers on a friend's Dodge Charger RT. Long story short, the header installation on the big block 440 cubic inch engine became a nightmare. We purchased model specific parts from a reputable Mopar specialist that designed the headers specifically for the Dodge Charger application. In addition, interference with the upper control arms and the tie rods became another issue. After we completed the installation the true problems began to surface. In order to clear some suspension parts the driver side header becomes the lowest part under the automobile. After going over a few speed bumps the tubes that carried exhaust gases from the front cylinders became completely smashed closed. Instead of increasing efficiency the end result became exactly the opposite. In fact, you can even find an article about nitrous oxide upgrades you can put in the trunk to provide the boost you're looking for. But no matter where we decide to boost performance, deciding to upgrade the exhaust headers maximizes the benefits of all the other alterations. I'm talking about cars like the Chevrolet Malibu Super Sport and the Ford Mustang pony cars. These automobiles utilized some of the most inefficient exhaust manifolds ever created by man. It's not that the original designers of these engines did not understand volumetric efficiency, they just approached the horsepower wars in a different way. They decided to increase combustion ratios and cubic inches to achieve the desired performance level. Of course, they also had leaded fuel available to them at the time. This forced them in the direction of improving the intake and exhaust cycles on modern automobiles.

Therefore, the general rule of thumb becomes the newer the automobile the less performance gains you'll find from upgrading the intake and exhaust manifolds. Why It's because the automotive manufacturers upgrade the exhaust headers on their own. They also do a good job on the intake side of manufacturing efficient cold air intakes and intake plenums installed on the assembly line. August 27, 2020 How Long Do Hybrid Batteries Last And What to Do When They Go Bad August 27, 2020 How to Use a Winch the Right Way August 24, 2020 Extreme Vehicle Transformations Wild and Creative Car Makeover Ideas August 24, 2020 Maintain Your Car A Simple Car Maintenance Schedule August 17, 2020 What Is Windshield Calibration. A Simple Guide August 12, 2020 10 Incredibly Common Car Problems Every Car Owner Faces August 10, 2020 How to Negotiate Car

Price 5 Tips to Get the Best Deal August 10, 2020 Search Motor Era. Dont waste time calling around to your local bookstores or waiting for a repair manual to arrive by mail. Get access to our 1993 Dodge Dakota repair information right now, online. Find your 1993 Dodge Dakota repair manual right now at Chilton. All Dakota manuals are in pdf format for quick easy download. No special software required to download a manual. Once downloaded, feel free to save the manual to your downloads folder or desktop forever. It is a vehicle manual used for learning how to fix or repair the automobile back to working order. The digital handbook can help guide the mechanic through maintenance, troubleshooting, service and overhaul of the vehicles main components. It covers every aspect of repair—from rebuilding the engine to changing the brake pads—a Dodge Dakota repair manual covers it all. The latest model of this beauty features unibody construction and amazing interiors. Its available in different trim levels and has several powerful engine options. While the vehicle is highly reliable, it may need repairs from time to time.

<http://www.a-fairys-choice.com/wp-content/plugins/formcraft/file-upload/server/content/files/162754e3084a9f--brother-p-touch-3600-user-manual.pdf>

Taking the pickup to a mechanic can be very costly, especially if its a small job. This is why it may be a good idea to perform small repair work on your own. This will not only help you save money but time as well. This is why you need a Download Dodge Dakota repair manual. It's a manual that's written keeping you in mind. It covers everything from maintenance to troubleshooting to inspection to repair. Also known as a shop manual or a service manual, the manual is suitable for professionals as well since it contains not only basic howto guides and information but also complex and advanced particulars. It works as an assistant, telling you what to do when things go wrong. Plus, it can also help take care of future problems by giving you the opportunity to inspect your vehicle in a proper manner. The manual is specifically designed for Dodge Dakota and has detailed instructions, written in clear manners. It's very easy to navigate and you will find all the information that you need here. Its highly specific with reliable calculations and measurements to reduce the effort on your part. Models Ford gearboxes. Faults bridges Ford Foton GAC Geely The history of Geely. Under the brand name Dodge are produced passenger cars, pickup The company was founded in 1900 by brothers Dodge for the production of automotive components. Issue own cars began in 1914. Dodge Company was sold to Chrysler in 1928, Its main activity was the issue of components for the emerging automotive industry. Having achieved success in this area, the Dodge The first car Dodge Brothers, which was later jokingly nicknamed Betsy old woman, abandoned factory November 14, 1914 followed by the end of the year another 249 Dodges made Each of them on the upper radiator tank sported a proprietary company logo a globe placed at the center of the star of David brothers remember their roots. By 1920, In addition, the heirs of the brothers and besides widows have no one left, received 50% of the share capital.

BANHTRUNGTHUVIP.COM/upload/files/brady-markware-manual.pdf

But both widows entrepreneurial talent This man was Walter Chrysler, and in 1928 the company Dodge WC supplied to the USSR under the Lend Lease Like other US automakers, Dodge offered customers prewar model. The most famous models of the brand Dodge 1960 70ies were sports coupe Challenger and Charger. In an attempt to gain a foothold in the compact cars segment, the company began to sell Japanese Mitsubishi Colt small car under its own brand Dodge Colt. Dodge WC continued to release under the name Dodge Power Wagon. In the future, this car served as the basis for a family of pickups, including the Dodge Ram. However, having received state aid, the Chrysler was able to avoid bankruptcy. As part of the anticrisis program was created several new The most popular Regis 1980 Aspen, Colt, Diplomat, Mirada, Omni, St. Regis 1981 Aries, Colt, Diplomat, Mirada, Omni, St. Thank you Ra All content on the site is taken from free sources and is also freely The site administration does not bear any responsibility for illegal actions, and any damage incurred by the copyright holders. All materials posted on this site for If you are the

copyright owner of the materials posted on this site contact us. The company was founded in 1900, but didn't begin producing cars until 1914. Up until then, they were a parts supplier to Detroit-based car makers. They have an extensive range of performance vehicles, as well as lower-priced variants of Chrysler-badged models. They are manufactured under the Ram brand, which is well-known for models like the 2500, the 3500 and the 5500. Dodge introduced a line called "Adult Toys" in the 1970s to help boost their truck sales, which included various customized versions of popular models. The purpose-built Ramcharger was manufactured in 1974 and features a powerful V8 engine. This model was redesigned in 1994 and followed this up with the Durango model in 1997. Dodge vehicles are sold throughout the world, including Europe, Canada and Brazil.

At Haynes we have an extensive selection of Dodge repair manuals for various models. Get all the technical information, how-to guides and other helpful information for your Dodge repairs and services. The 13-digit and 10-digit formats both work. Please try again. Please try again. Used GoodNo writing, complete and fully functional. Ships direct from Amazon! Something we hope you'll especially enjoy. FBA items qualify for FREE Shipping and Amazon Prime. Learn more about the program. Then you can start reading Kindle books on your smartphone, tablet, or computer - no Kindle device required. In order to navigate out of this carousel please use your heading shortcut key to navigate to the next or previous heading. In order to navigate out of this carousel please use your heading shortcut key to navigate to the next or previous heading. Register a free business account. Each manual contains easy-to-follow step-by-step instructions linked to hundreds of photographs and illustrations. Included in every manual: troubleshooting section to help identify specific problems; tips that give valuable short-cuts to make the job easier and eliminate the need for special tools; notes, cautions and warnings for the home mechanic; color spark plug diagnosis and an easy-to-use index. To calculate the overall star rating and percentage breakdown by star, we don't use a simple average. Instead, our system considers things like how recent a review is and if the reviewer bought the item on Amazon. It also analyzes reviews to verify trustworthiness. Please try again later. Isabelle S. 5.0 out of 5 stars Finally got my 94 Dakota running and was getting tired of YouTube not having videos to my exact truck. This book is my bible. Not only to have derailed trouble shooting, but it also provides detailed info on actual maintaining your vehicle overall with preventive maintenance and care. I also purchased it used and it was very well maintained. No rips stains. Still had that classic book smell.

I didn't realize that there were separate flashers for the turn signals and the hazard lights. Now I know. Listen to the manual. Price was right I would recommend this if you have some know-how. He has really found in to be informative and extremely useful. The language is easy to understand for a layman too. He really loves it! They are like chapters in his Bible. He loves to work on cars and trucks, but the increasing complexity of vehicle systems takes away a lot of his fun. The Haynes Manuals gives some of it back. They are understandable, thorough, correct. Sorry, we failed to record your vote. Please try again. Page 1 of 1 Start over Page 1 of 1 In order to navigate out of this carousel please use your heading shortcut key to navigate to the next or previous heading. We do it ourselves to help you do it yourself, and whatever your mechanical ability, the practical step-by-step explanations, linked to over 900 photos, will help you get the job done right. Regular servicing and maintenance of your Dodge Dakota can help maintain its resale value, save you money, and make it safer to drive. Take your entire manual with you on every journey. The Durango featured four-speed automatic transmission, and had options of 3.7 liter V6, or 4.75.7 liter V8 engines, depending on the trim level. The Durango had independent front suspension and leaf spring rear suspension, with a stabilizer bar to control body roll. Power-assisted front disc brakes were standard. The servicing routine includes weekly tire and tire pressure checks, three monthly engine oil and filter changes, and annual brake system checks. For detailed mechanical guidance, purchase a Dodge Durango 2005-2011 repair manual from Haynes today. Available in either print or digital formats. Disclaimer Sedo maintains no relationship with third party advertisers. Reference to any specific service or

trade mark is not controlled by Sedo nor does it constitute or imply its association, endorsement or recommendation.

Most likely this means that the seller is no longer selling this product. By continuing to use this website you are giving consent to cookies being used. Mount the new belt, the distribution being at setting point P.M.S.. Place the tensioning cam and tighten the distribution belt by means of the MOT 113501 device. Block the tensioning cam. Make the distribution belt vibrating the measurement is validated by a "bip" of the device. Block the tightener and tighten its nut at the required moment of 3 daNm. Rotate 5 and a half turns the crankshaft. Unscrew the cam nut. Tighten again the belt until obtaining a value between 145 and 185 Hz. Obligatory tighten the tensioning cam nut at 5 daNm. NOTE If the value is higher than 275 Hz, the distribution belt is to be replaced with a new one.

<https://ayurvedia.ch/bose-ps48-iii-service-manual>